



Supplement

E Series

El último elemento de las indicaciones en el pedido constituyen las medidas en decimas de milímetros, pero siempre en cifras redondas a cero o a cinco para evitar una multiplicidad de tamaños.

Una excepción hacemos con los cristales cuadrados R y RX. Ambas referencias se suministran en el tipo "Konkav" entre la medida de 140 x 140 hasta la medida de 260 x 260 por cada 0,1 de milímetro, o sea 140 x 140, 141 x 141, 142 x 142, etc.

Las formas R y T, que se especifican claramente por las medidas, están listadas en el catálogo en tablas. Los puntos en las columnas a derecho indican cada vez los tipos disponibles, o sea Standard, Optik o Konkav. El catálogo contiene únicamente imágenes de aquellas formas de cristales R y T, cuando se trata de cristales con ángulos redondos, oblicuos o otras variaciones. Se puede poner la caja de reloj en la imagen para tomar la medida.

De la forma de cristal B el catálogo contiene todas las medidas tanto en forma de tablas como en forma de imágenes. El tamaño apropiado puede ser escogido tanto según medidas como según imágenes.

El catálogo contiene imágenes en tamaño natural de todos los cristales de las formas L, E, D H y G como también de los cristales de formas especiales. Para estos cristales desistamos de una indicación en tablas dado que se puede escoger tales cristales únicamente según imágenes. La indicación de medidas fue hecha en decimas de milímetros sin redondeándolas.

En este suplemento se sirven hallar después de los tipos Standard, Optik y Konkav también el tipo Plano. Este tipo se suministra embalado en sobres blancos, imprenta verde. Se trata de cristales sin espacio interior, completamente plano de ambos lados. La sección transversal de todos los cristales planos de forma está siempre indicada en las imágenes.

Un pedido debe incluir los siguientes datos:

Cantidad, Tipo de cristal, Letra distintiva, medidas del cristal.

p. e.: 10 pzas. Konkav T 210 x 230 x 160

Por la regla general los tamaños que no están listados en el catálogo pueden ser entregadas por la fábrica por producción especial. En estos casos hace contar con un plazo de entrega retrasado en función del tiempo necesitado para la producción y la expedición.



Ellipsenform • Elliptical shape Forme elliptique • Eliptico

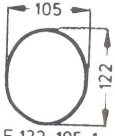

E 122×105.1
Konkav

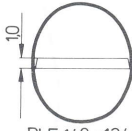

Pl.E 149×124

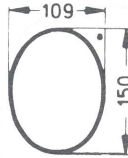

E 150×109.1
Konkav

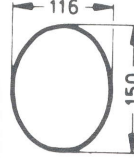

E 150×116.1
Konkav

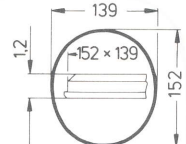

Pl. E 152 × 139 Talon

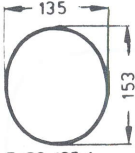

E 153×135.1
Konkav

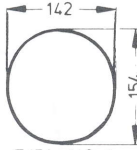

E 154 × 142.1
Konkav

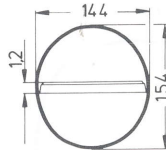

Pl. E 154 × 144

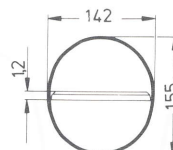

Pl. E 155 × 142

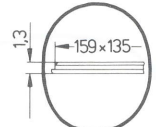

Pl. E 159 × 135 Talon

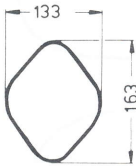

E 163×133.1
Konkav

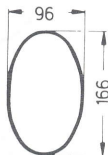

E 166 × 96.1
Konkav

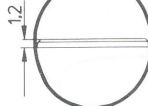

Pl. E 167 × 150

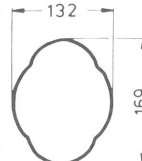

E 169 × 132.1
Konkav

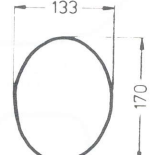

E 170 × 133.1
Konkav

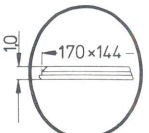

Pl. E 170 × 144 Talon

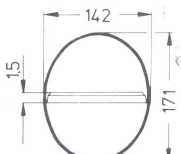

Pl. E 171 × 142

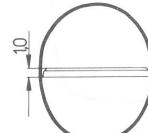

Pl. E 176 × 143

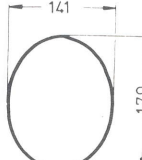

E 179 × 141.1
Konkav

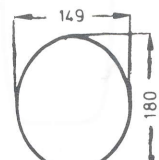

E 180 × 149.1
Konkav

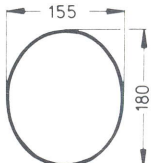

E 180 × 155.1
Konkav

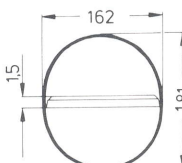

Pl. E 181 × 162

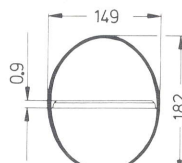

Pl. E 182 × 149

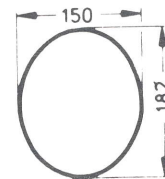

E 182 × 150.1
Konkav

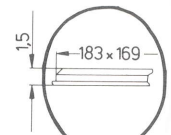

Pl. E 183 × 169 Talon

Ellipsenform • Elliptical shape

Forme elliptique • Eliptico

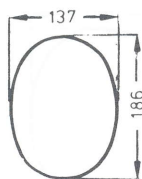

E 186×137.1
Konkav

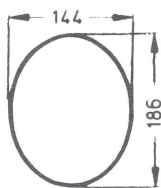

E 186×144.1
Konkav

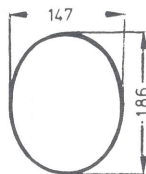

E 186×147.1
Konkav

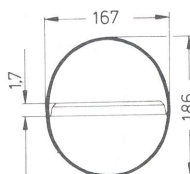

Pl. E 186 × 167

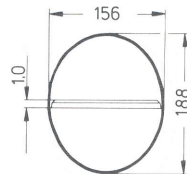

Pl. E 188×156

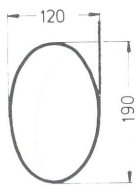

E 190×120.1
Konkav

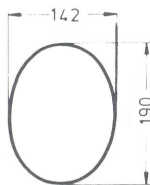

E 190×142.1
Konkav

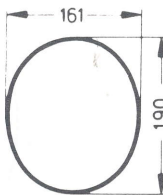

E 190×161.1
Konkav

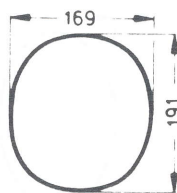

E 191×169.1
Konkav

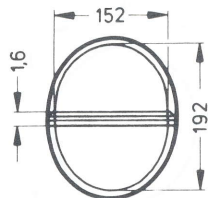

PL. NE 192×152

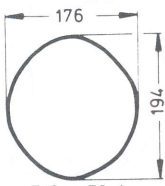

E 194×176.1
Konkav

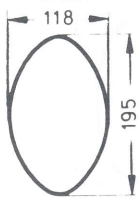

E 195×118.1
Konkav

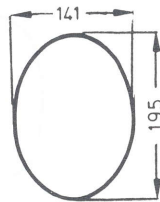

E 195×141.1
Konkav

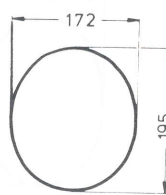

E 195×172.1
Konkav

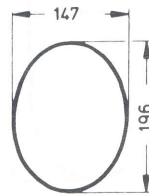

E 196×147.1
Konkav

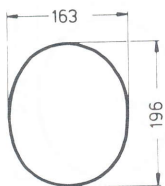

E 196×163.1
Konkav

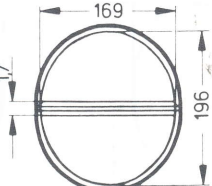

Pl. NE 196×169

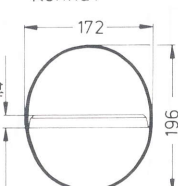

Pl. E 196×172

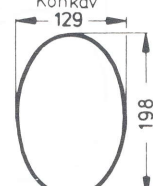

E 198×129.1
Konkav

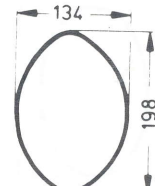

E 198×134.1
Konkav

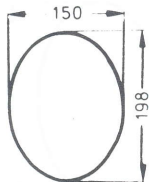

E 198×150.1
Konkav

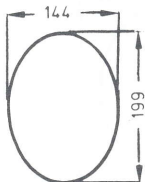

E 199×144.1
Konkav



E 200×88.1
Konkav

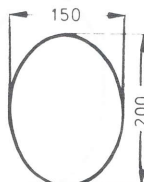

E 200×150.2
Konkav

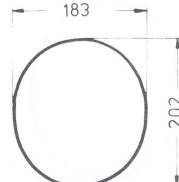

E 202×183.1
Konkav



Ellipsenform • Elliptical shape
Forme elliptique • Eliptico

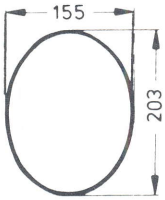

E 203x155.1
Konkav

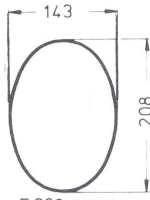

E 208x143.1
Konkav

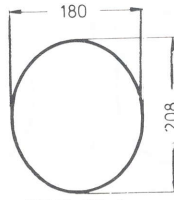

E 208 180.1
Konkav

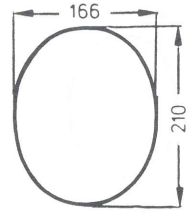

E 210 x 166 1
Konkav

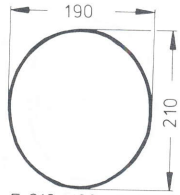

E 210 x 190 - 1
Standard

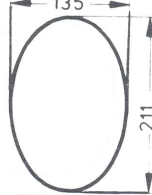

E 211x135.1
Konkav



Pl.E 212x100

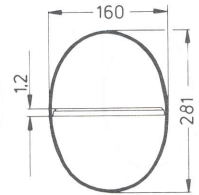

Pl. E 218 x 160

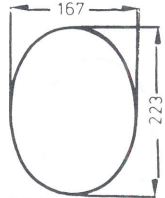

E 223x167.1
Konkav



E 225x162.1
Konkav

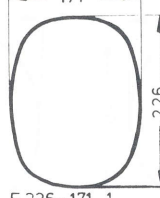

E 226x171.1
Konkav

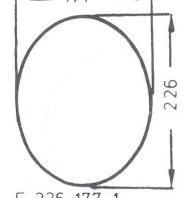

E 226x177.1
Konkav

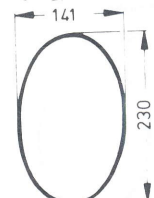

E 230x141.1
Konkav

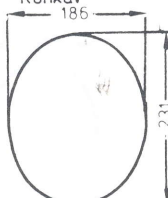

E 231x186.1
Konkav

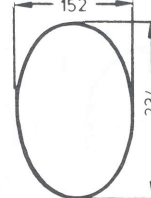

E 234x152.1
Konkav

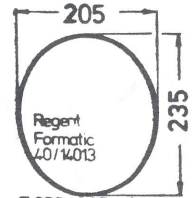

E 235x205.1
Konkav

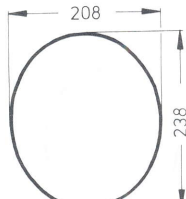

E 238 x 208 - 1
Konkav

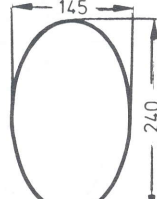

E 240x145.1
Konkav

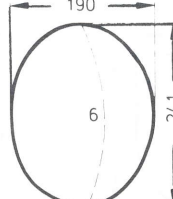

EZ 241x190.1
Konkav

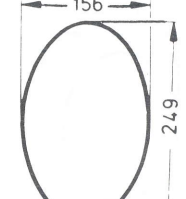

E 249x156.1
Konkav

Ellipsenform • Elliptical shape
 Forme elliptique • Eliptico

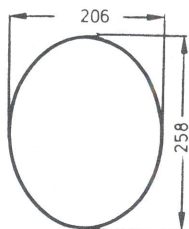

E 258×206.1
Konkav

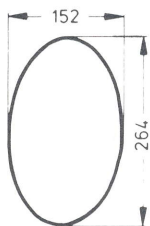

E 264×152.1
Konkav



E 269×104.1
Konkav

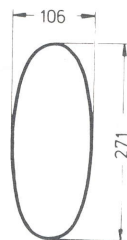

E 271×106.1
Konkav



E 275×180.1
Konkav

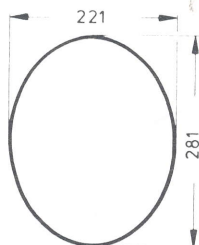

E 281×221.1
Konkav

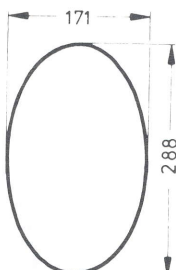

E 288×171.1
Konkav



E 289×257.1 Talon
Konkav

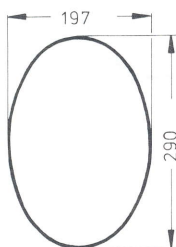

E 290×197-1
Konkav

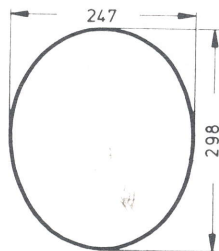

E 298×247.1
Konkav

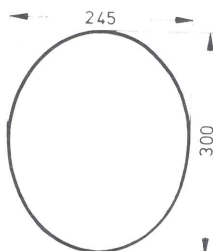

E 300×245.1
Konkav

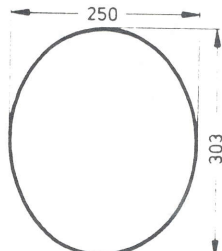

E 303×250.1
Konkav

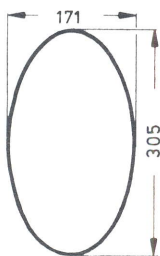

E 305×171.1
Konkav

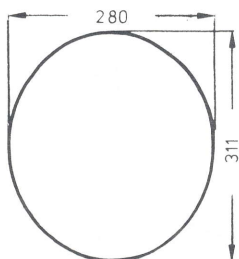

E 311×280.1
Konkav

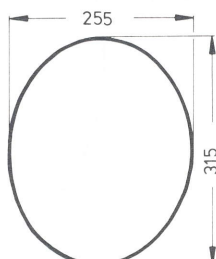

E 315×255.1
Konkav

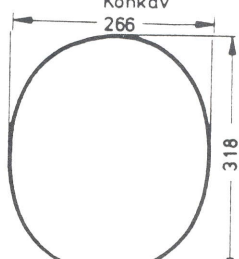

E 318×266.1
Konkav



Ellipsenform • Elliptical shape
Forme elliptique • Eliptico

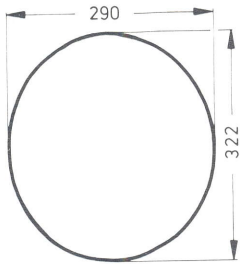

E 322×290.1
Konkav

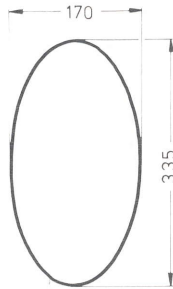

E 335×170.1
Standard

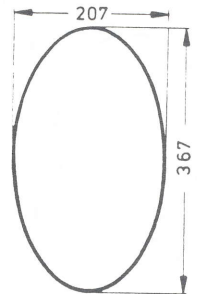

E 367×207.1
Konkav

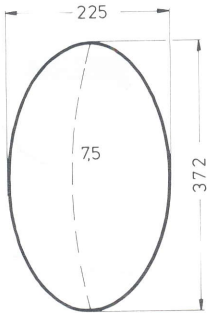

EZ 372×225.1
Konkav

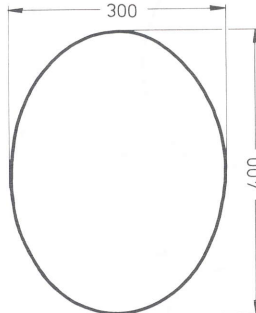

E 400×300.1
Standard

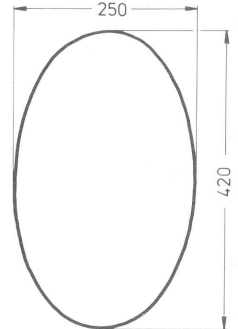

E 420×250.1
Standard

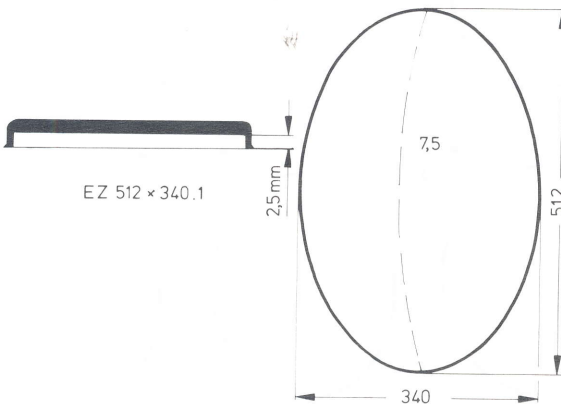

EZ 512 × 340.1